

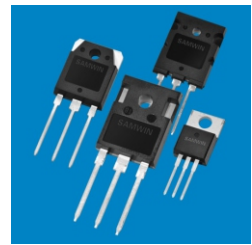

芯派科技  
SEMIPOWER

*Samwin*<sup>®</sup>

## PRODUCT SELECTION GUIDE

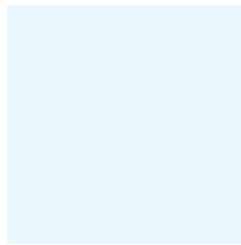
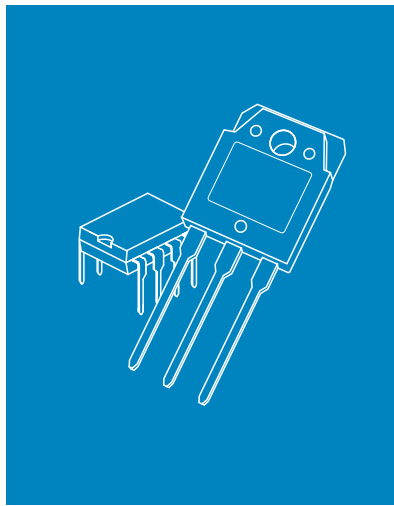

SEMIPOWER ELECTRONIC TECHNOLOGY





### COMPANY INTRODUCTION

Semipower Electronic Technology established in 2008, is a high tech enterprise specializes in R&D & sales of semiconductor power devices & power management IC. Headquartered in Xi'an, China, Semipower has branch offices in Shanghai, Shenzhen, Taiwan for sales & marketing, advanced technology development, technology collaboration, engineering, quality management & logistics.

Samwin is the registered trademark of Semipower. Our product line includes 40V~1000V MOSFETs, 600V~1200V IGBTs, 20V~1000V bridge rectifiers, Schottky diodes & fast recovery diodes which are widely applied in consumer, industrial, automotive electronics, as well as in the field of renewable energy. Key customers of Semipower includes Huawei, Vivo, Oppo, Xiaomi, Apple, Samsung, LG, Asus, Lenovo, HP, Amazon, Skyworth, Philips, Emerson, TGOOD which are leading companies in their respective business domain. We have been widely recognized in the power electronics industry for our innovative products & excellent track record in product quality.

In order to ensure the quality & reliability of Semipower products, we have invested heavily in our Semiconductor Device Test & Application Center in Xi'an. Comprehensive tests ranging from device characteristic & parametric tests, reliability test, failure analysis & system level application test can be fully conducted in house. The test center has attained ilac-MRA international lab certification & CNAS China lab certification. We also offer third party test services to our customers & other companies.

Semipower continues to invest in the future to develop leading-edge technology & innovative products to meet the market needs. We uphold the philosophy of "Innovation, honesty, harmony, gratitude" & strive to offer complete & high quality products & services to our customers as always. Choose Semipower as your partner & let Semipower products be your best choice for green power.



- ✓ National high-tech enterprise
- ✓ National IC design enterprise
- ✓ National CNAS certified lab
- ✓ China power supply association council member
- ✓ Shaanxi province semiconductor power device test & application center
- ✓ Shaanxi province semiconductor industry association council member
- ✓ Xi'an enterprise technology center
- ✓ ISO9001:2008 Quality management system certification
- ✓ ISO14001:2004 Environmental management system certification
- ✓ Products certified by National Defense Industry Council in reliability evaluation
- ✓ Products attained REACH & HF certification

## SEMIPOWER SEMICONDUCTOR DEVICE TEST & APPLICATION CENTER



Device Test Lab



Reliability Test Lab



Failure Analysis (FA)  
Test Lab

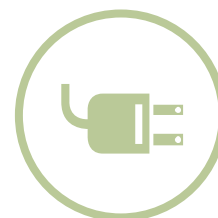

Application & System  
Test Lab

Semipower Semiconductor Device Test & Application Center is an advanced lab for power devices & power management IC test & analysis. Over the years, significant investment has been made to acquire high precision test equipment operated by highly trained personnel. Comprehensive tests ranging from device characteristic & parametric test, reliability test, failure analysis & system level application test can be fully conducted in house. The center has attained ilac-MRA international lab certification & CNAS China lab certification. Third party test services can be offered to customers & other companies.

### TECHNOLOGY COLLABORATION PARTNERS

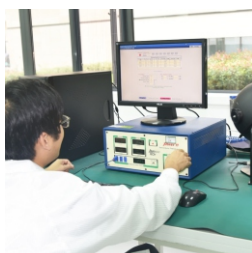
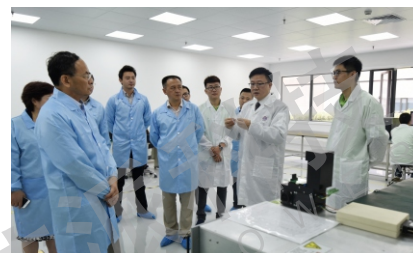

• High voltage MOSFET part numbering

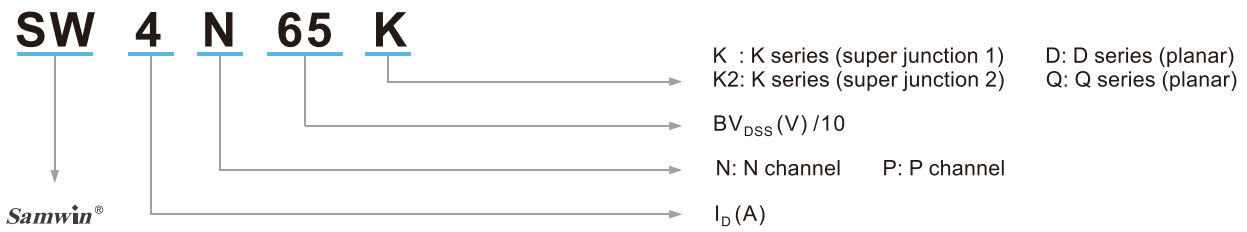

• Low voltage MOSFET part numbering

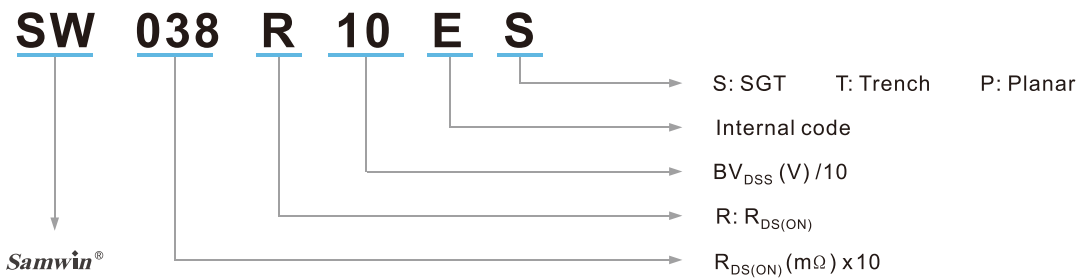

Common device packages

Samwin®



TO-251 (IPAK)



TO-252 (DPAK)



TO-220

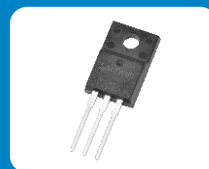

TO-220F

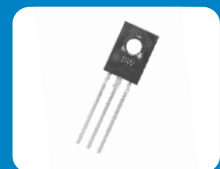

TO-126

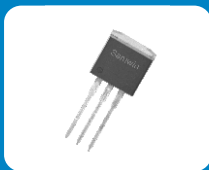

TO-262



TO-263

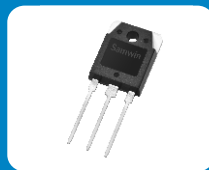

TO-3P

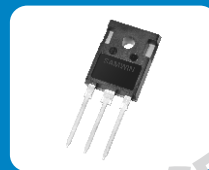

TO-247



SOP-8

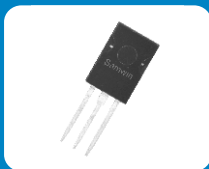

SOT-82

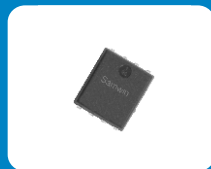

DFN 5\*6



SOT-23



SOT-223

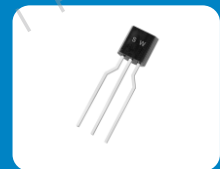

TO-92



● LOW VOLTAGE MOSFET - 01

Voltage Rating	Part Number	BV <sub>DSS</sub> (V)	I <sub>D</sub> (A) 25°C	R <sub>DS(ON)</sub> (Ω) (V <sub>GS</sub> =10V)		Q <sub>g</sub> (nC) (V <sub>GS</sub> =10V)	V <sub>GS</sub> (V)	V <sub>GS(H)</sub> (V) Max.	Structure	Package
				Typ.	Max.					
-40	SW028P04	-40	-7.5	0.019	0.028	48	20	-3	Trench	SOP-8
-30	SW50P03	-30	-85	0.0085	0.011	69	20	-1.9	Trench	TO-251、DFN5*6
	SW15P03	-30	-15	0.01	0.014	48	20	-2.5	Trench	SOP-8
	SW4459	-30	-6.5	0.037	0.049	12.5	20	-3	Trench	SOP-8
	SW9435	-30	-5.3	0.0435	0.05	19	20	-3	Trench	SOP-8
	SW417J	-30	-4	0.054	0.065	10	20	-2	Trench	SOT-23
-20	SW15P02	-20	-15	0.009	0.012	91	12	-0.8	Trench	TO-251、TO-252、DFN5*6、DFN3*3
20V	SWVS22	20	4	0.036	0.045	5.1	12	1	Trench	SOT-23
	SW2G413	20	6	0.025	0.03	7.6	12	1	Trench	SOT-23
	SW3416J	20	7	0.018	0.022	12.5	12	1	Trench	SOT-23
	SW180R02VT	20	12	0.0134	0.0168	14	10	0.75	Trench	DFN3*3
	SW160R02VT	20	16	0.0123	0.0154	15.4	10	1	Trench	DFN3*3
	SW045R02VT	20	80	0.0046	0.0058	49	12	1.3	Trench	DFN3*3
30V	SW3406	30	4	0.046	0.057	8	20	3	Trench	SOT-23
	SW20N03A	30	5.7	0.019	0.025	14	20	3	Trench	DFN3*3
	SW3404	30	6	0.028	0.035	5.2	20	3	Trench	SOT-23
	SW110R03VT	30	55	0.014	0.0175	21	20	3	Trench	TO-252、DFN3*3
	SW026R03VT	30	80	0.0035	0.0044	113	20	1.8	Trench	DFN5*6、TO-252
	SW055R03VT	30	80	0.0062	0.007	25	20	1.8	Trench	TO-251、TO-252、DFN3*3
	SW027R03VT	30	120	0.0036	0.0045	110	20	2.35	Trench	TO-252
40V	SW15N04V	40	15	0.0058	0.007	49	20	2.5	Trench	SOP-8、DFN5*6
	SW30N04V	40	30	0.0027	0.004	130	20	3	Trench	SOP-8
	SW160R04VT	40	30	0.017	0.024	27	20	2	Trench	SOP-8、TO-251、DFN5*6
	SW60N04V	40	60	0.023	0.029	127	20	2.5	Trench	DFN5*6
	SW80N04V	40	80	0.006	0.008	49	20	2.5	Trench	TO-251、TO-252
	SW038R04VT	40	95	0.0038	0.0048	105	20	2.25	Trench	TO-220
	SW029R04ET	40	120	0.0025	0.0031	151	20	4	Trench	TO-220、TO-263
	SW190N04A	40	190	0.0031	0.0045	112	25	4	Trench	TO-220
	SW030R04VT	40	130	0.0029	0.0036	120	20	3	Trench	TO-220
45V	SW230R45VT	45	6	0.02	0.025	26	20	2	Trench	SOP-8
	SW120R45VT	45	12	0.0105	0.015	45	20	2.2	Trench	SOP-8、TO-251、DFN5*6
	SW230R45VT	45	30	0.019	0.024	26	20	2	Trench	TO-251
60V	SW2N7002	60	0.3	1.75	2	1.7	20	2.5	Trench	SOT-23
	SW350R06VT	60	5	0.033	0.041	21	20	2.4	Trench	SOP-8
	SW6016	60	8	0.011	0.012	69	20	2.5	Trench	SOP-8
	SW7960U	60	8	0.014	0.0175	58	20	2.5	Trench	SOP-8
	SW15N06V	60	15	0.0075	0.0085	79	20	2.5	Trench	SOP-8
	SW350R06VT	60	24	0.032	0.04	21	20	2.4	Trench	TO-251、TO-252
	SW30N06U	60	30	0.0254	0.04	27	20	4	Trench	TO-251、TO-252
	SW088R06VT	60	40	0.0092	0.0115	48	20	2.4	Trench	TO-251、TO-252、SOP-8、DFN5*6
	SW40N06V	60	40	0.0084	0.01	83	20	2.5	Trench	DFN5*6
	SW50N06A	60	50	0.017	0.019	28	20	4	Trench	TO-252
	SW50N06V2	60	50	0.017	0.019	28	20	2.5	Trench	TO-252
	SW50N06V	60	50	0.01	0.013	43	20	3	Trench	TO-220、TO-252
	SW130R06VT	60	58	0.012	0.017	55	20	2.4	Trench	SOP-8、TO-251、DFN5*6

Note: The product selection guide only contains representative products. Complete offerings can be found in Semipower website.

● LOW VOLTAGE MOSFET - 02

Voltage Rating	Part Number	BV <sub>DSS</sub> (V)	I <sub>D</sub> (A) 25°C	R <sub>DS(ON)</sub> (Ω) (V <sub>GS</sub> =10V)		Q <sub>9</sub> (nC) (V <sub>GS</sub> =10V)	V <sub>GS</sub> (V)	V <sub>GS(H)</sub> (V)	Structure	Package
				Typ.	Max.					
60V	SW069R06VT	60	60	0.007	0.0087	83	20	2.4	Trench	TO-251, DFN5*6
	SW60N06V1	60	60	0.011	0.012	72	20	2.5	Trench	TO-251
	SW60N06V2	60	60	0.0082	0.0085	73	20	2.5	Trench	TO-251
	SW069R06VT	60	60	0.006	0.0075	83	20	2.4	Trench	TO-251, DFN5*6, TO-252
	SW075R06ET	60	65	0.0076	0.0095	78	20	4	Trench	TO-220, TO-263, TO-252, TO-251
	SW072R06ET	60	75	0.0069	0.0087	84	20	4	Trench	TO-220, TO-263, TO-252, TO-251
	SW80N06V1	60	80	0.0055	0.0065	103	20	3	Trench	TO-251, DFN5*6
	SW80N06VS	60	80	0.0073	0.01	30	20	2.5	SGT	TO-251
	SW110R06VT	60	75	0.01	0.014	69	20	2.5	Trench	TO-251, DFN5*6, SOP-8
	SW039R06ET	60	90	0.0036	0.0045	108	20	4	Trench	TO-220, TO-263
	SW085R06VT	60	100	0.0073	0.009	87	20	2.3	Trench	TO-220
	SW024R06VT	60	100	0.0024	0.003	70	20	2.4	Trench	DFN5*6
	SW3205B	60	110	0.0048	0.0065	80	20	4	Trench	TO-220
	SW029R06ET	60	120	0.0026	0.0033	168	20	4	Trench	TO-220, TO-263
SW031R06ET	60	120	0.003	0.0038	148	20	4	Trench	TO-220, TO-263	
68V	SW75N75B	68	75	0.0076	0.0085	76	25	4	Trench	TO-220
75V	SW180N75A	75	180	0.0028	0.0045	178	20	4	Trench	TO-220
80V	SW70N08V	80	70	0.012	0.015	84	20	2.5	Trench	TO-251
	SW75N08	80	75	0.0093	0.0116	74	20	4	Trench	TO-252
	SW09R08V	80	80	0.009	0.0115	77	20	2.5	Trench	DFN5*6
	SW80N08V	80	80	0.01	0.012	79	20	2.5	Trench	TO-251
	SW80N08V1	80	80	0.009	0.0113	79	20	2.5	Trench	TO-251, DFN5*6
	SW125R08VS	80	50	0.01	0.013	30	20	2.4	SGT	SOP-8
	SW100R08VS	80	55	0.01	0.0128	77	20	2.4	SGT	DFN5*6
	SW078R08ET	80	60	0.0079	0.0099	79	20	4	Trench	TO-220, TO-263
	SW072R08ET	80	80	0.0066	0.0083	60	20	4	Trench	TO-220, TO-263
	SWP090R08ET	80	80	0.009	0.0105	77	20	4	Trench	TO-220
	SW070R08VT	80	80	0.0075	0.0094	88	20	2.3	Trench	TO-251
	SW090R08ET	80	80	0.009	0.0105	77	20	4	Trench	TO-220, TO-263
	SW80N08A	80	80	0.0069	0.0092	82	25	4	Trench	TO-220
	SW051R08ES	80	90	0.0052	0.0065	44	20	4	SGT	TO-220, TO-263
	SW045R08ET	80	100	0.0039	0.0049	139	20	4	Trench	TO-263
	SW110N08A	80	110	0.0048	0.0072	107	20	4	Trench	TO-220
SW051R08ES-2	80	120	0.0052	0.0065	44	20	4	SGT	TO-220, TO-263	
SW035R08ET	80	120	0.0033	0.0043	185	20	4	Trench	TO-263	
SW150N08A	80	150	0.0041	0.0052	143	20	4	Trench	TO-220	
90V	SW062R09VS	90	90	0.0078	0.0098	64	20	2.3	SGT	TO-251, TO-252, TO-220, SOP-8
95V	SW106R98VS	95	35	0.0116	0.014	117	20	3	SGT	DFN5*6, TO-252
	SW106R95VS	95	35	0.0116	0.014	117	20	3	SGT	DFN5*6, TO-252
	SW70N10V	95	70	0.0117	0.013	117	20	3	Trench	TO-251, TO-252
100V	SW2N10	100	2	0.019	0.024	13	15	3	Trench	SOT-23
	SW3N10	100	3	0.08	0.1	21	16	2.5	Trench	TO-252
	SW9N10V1	100	9	0.115	0.138	5.6	20	2.5	Trench	TO-252
	SW9N10V	100	9	0.086	0.108	10	16	2.5	Trench	TO-252
	SW19N10	100	19	0.1	0.12	15	25	4	Trench	TO-220, TO-252
	SW540	100	32	0.032	0.04	48	20	4	Trench	TO-220, TO-252



● LOW VOLTAGE MOSFET - 03

Voltage Rating	Part Number	BV <sub>DSS</sub> (V)	I <sub>D</sub> (A) 25°C	R <sub>DS(ON)</sub> (Ω) (V <sub>GS</sub> =10V)		Q <sub>g</sub> (nC) (V <sub>GS</sub> =10V)	V <sub>GS</sub> (V)	V <sub>GS(th)</sub> (V)	Structure	Package
				Typ.	Max.					
100V	SW340R10VT	100	34	0.032	0.04	61	20	3	Trench	TO-220
	SW35N10V	100	35	0.0115	0.0124	117	20	3	Trench	DFN5*6
	SW200R10VT	100	36	0.0187	0.023	86	20	2.5	Trench	TO-251、TO-252、SOP-8
	SW100R10VT	100	69	0.0094	0.012	73	20	2.3	Trench	TO-220
	SW069R10VS	100	70	0.0071	0.0089	45	20	2.4	SGT	TO-251、TO-252、TO-220、DFN5*6
	SW055R10ET	100	100	0.0045	0.0056	145	20	4	Trench	TO-220、TO-263
	SW100N10A	100	100	0.0059	0.0074	127	20	4	Trench	TO-220
	SW100N10B	100	100	0.0067	0.0105	106	20	4	Trench	TO-220
	SW026R10ET	100	120	0.0029	0.0036	312	20	4	Trench	TO-251、DFN5*6
	SW038R10ES	100	120	0.0036	0.0045	132	20	4	SGT	TO-220、TO-263、TO-247
	SW042R10ES	100	120	0.0044	0.0055	106	20	4.3	SGT	TO-220、TO-263
	SW045R10ES	100	120	0.0045	0.0056	71	20	4	SGT	TO-220、TO-263
SW036R10ES	100	130	0.0034	0.0043	156	20	4	SGT	TO-220、TO-263	
SW150N10A	100	150	0.0048	0.0056	160	20	4	Trench	TO-220	
120V	SW160R12VT	120	50	0.0146	0.018	64	20	2.3	Trench	TO-220
150V	SW170R15ET	150	66	0.0157	0.0196	164	20	4	Trench	TO-220FB
	SW90R15ET	150	100	0.009	0.013	79	20	4.5	Trench	TO-220FB

● HIGH VOLTAGE PLANAR MOSFET - 01

Voltage Rating	Part Number	BV <sub>DSS</sub> (V)	I <sub>D</sub> (A) 25°C	R <sub>DS(ON)</sub> (Ω) (V <sub>GS</sub> =10V)		Q <sub>g</sub> (nC) (V <sub>GS</sub> =10V)	V <sub>GS</sub> (V)	V <sub>GS(th)</sub> (V)	Structure	Package
				Typ.	Max.					
200V	SW630A	200	10	0.35	0.44	22	30	4	Planar	TO-220、TO-252
	SW630A1	200	10	0.34	0.41	17	30	4	Planar	TO-220
	SW630D	200	9	0.27	0.4	20	30	4	Planar	TO-220、TO-252
	SW630	200	10	0.3	0.41	21	30	4	Planar	TO-220、TO-220F、TO-252
	SW640	200	18	0.12	0.18	48	30	4	Planar	TO-220、TO-3P
	SW640D	200	18	0.15	0.18	38	20	4	Planar	TO-220、TO-220FT、TO-263
	SW20N20D	200	20	0.15	0.18	37	20	4	Planar	TO-252
250V	SW9N25D	250	9	0.37	0.45	20.3	25	4	Planar	TO-220、TO-252
	SW634	250	9	0.32	0.45	26	30	4	Planar	TO-220、TO-252
300V	SW5N30D	300	5	0.76	0.9	12	30	4.5	Planar	TO-220F、TO-251
400V	SW2N40DC	400	2	2.8	3.5	6.8	30	4.5	Planar	TO-251、TO-252
	SW2N40D	400	2	2.8	3.2	7	30	4.5	Planar	TO-92、SOT-223
	SW4N40DC	400	4	1.4	1.7	11.7	30	4.5	Planar	TO-251S、TO-252
	SW4N40D	400	4	1.4	1.7	8.5	30	4.5	Planar	SOT-223
	SW740D	400	10	0.4	0.5	35	30	4.5	Planar	TO-220、TO-220F
	SW740U	400	10	0.35	0.55	38	30	4	Planar	TO-220
500V	SW830D1	500	5	1.33	1.54	17	30	4.5	Planar	TO-220、TO-220F、TO-251、TO-252
	SW9N50D	500	9	0.68	0.8	31	30	4.5	Planar	TO-220、TO-220F、TO-252
	SW13N50D	500	13	0.46	0.52	47	30	4.5	Planar	TO-220F
	SW15N50D	500	15	0.22	0.3	92	30	4.5	Planar	TO-220F
	SW15N50	500	15	0.26	0.32	66	30	4	Planar	TO-220F
	SW18N50D	500	18	0.24	0.3	88	30	4.5	Planar	TO-220F、TO-247

● HIGH VOLTAGE PLANAR MOSFET - 02

Voltage Rating	Part Number	BV <sub>DSS</sub> (V)	I <sub>D</sub> (A) 25°C	R <sub>DS(ON)</sub> (Ω) (V <sub>GS</sub> =10V)		Q <sub>g</sub> (nC) (V <sub>GS</sub> =10V)	V <sub>GS</sub> (V)	V <sub>GS(th)</sub> (V)	Structure	Package
				Typ.	Max.					
500V	SW20N50D	500	20	0.19	0.25	82	30	4.5	Planar	TO-220F、TO-247
	SW24N50D	500	24	0.14	0.2	129	30	4.5	Planar	TO-247
550V	SW1N55D	550	1	4.5	6.5	7	30	4.5	Planar	TO-251
600V	SW601Q	600	0.185	330	700	1300	30	-	Planar	SOT-23
	SW1N60A	600	0.8	11.5	15	6	30	4.5	Planar	TO-92
	SW1N60DC	600	1	7	8.5	6.3	30	4.5	Planar	TO-252、SOT-223
	SW1N60D	600	1	6.6	8.5	6.8	30	4.5	Planar	TO-251、TO-251S、TO-92
	SW2N60DC	600	2	3.9	4.5	9.5	30	4.5	Planar	TO-251、TO-252
	SW2N60DB	600	2	3.9	4.5	10	30	4.5	Planar	TO-220F
	SW2N60B	600	2	3.8	4.5	7.5	30	4	Planar	TO-220F、TO-251、TO-252、TO-126
	SW4N60D	600	4	1.9	2.2	18	30	4.5	Planar	TO-220F、TO-251、TO-252、TO-251M、TO-251S
	SW4N60DC	600	4	2	2.2	17	30	4.5	Planar	TO-251、TO-252
	SW4N60DA	600	4	3.35	3.65	9.6	30	4.5	Planar	TO-220F、TO-251S、TO-252
	SW4N60T	600	4	2	2.5	14	30	4	Planar	TO-220F
	SW5N60D	600	5	1.9	2.2	17	30	4.5	Planar	TO-220F
	SW5N60T	600	5	1.5	2.1	15	30	4	Planar	TO-220F
	SW6N60D	600	6	1.4	1.7	23	30	4.5	Planar	TO-220F、TO-251N、TO-252
	SW7N60D	600	7	1.05	1.2	30	30	4.5	Planar	TO-220、TO-220F、TO-251、TO-252
	SW7N60R	600	7	0.9	1.25	19	30	4.5	Planar	TO-220
	SW7N60T	600	7	0.97	1.35	22	30	4	Planar	TO-220F
	SW8N60D	600	8	0.92	1	29	30	4.5	Planar	TO-262
SW10N60D	600	10	0.9	1.1	35	30	4.5	Planar	TO-220F	
SW12N60D	600	12	0.7	0.8	48	30	5	Planar	TO-220F	
SW13N60D	600	13	0.5	0.65	54	30	4.5	Planar	TO-220F	
SW16N60D	600	16	0.4	0.5	68	30	4.5	Planar	TO-220F	
SW18N60D	600	18	0.34	0.43	79	30	4.5	Planar	TO-220F	
650V	SW2N65D	650	2	3.9	4.5	9	30	4.5	Planar	TO-220F
	SW2N65DB	650	2	3.9	4.9	11	30	4.5	Planar	TO-220F
	SW4N65DB	650	4	1.7	2	20	30	4.5	Planar	TO-251
	SW4N65DC	650	4	1.95	2.6	17	30	4.5	Planar	TO-251、TO-251N-S2
	SW4N65D	650	4	2	2.6	18	30	4.5	Planar	TO-220、TO-220F、TO-252、TO-251N、TO-251M、TO-251S、TO-263、SOT-82
	SW4N65DD	650	4	2.4	2.9	16	30	4.5	Planar	TO-251N、TO-251N-S2、TO-220F、TO-220SF
	SW4N65DA	650	4	3.35	3.65	13	30	4.5	Planar	TO-251N、TO-251NX-S4、TO-220F、TO-252
	SW6N65D	650	6	1.3	1.7	22	30	4.5	Planar	TO-252
	SW7N65D	650	7	1.1	1.4	30	30	4.5	Planar	TO-220、TO-220F、TO-251、TO-251N、TO-252
	SW7N65DA	650	7	1.4	1.7	25	30	4.5	Planar	TO-251N
	SW7N65DD	650	7	1.1	1.5	28	30	4.5	Planar	TO-220F、TO-251N、TO-252
	SW7N65T	650	7	1.2	1.4	22	30	4	Planar	TO-251N
	SW8N65D	650	8	1.1	1.4	32	30	4.5	Planar	TO-220、TO-220F、TO-251、TO-251NX、TO-252
	SW8N65DB	650	8	1	1.2	34	30	4.5	Planar	TO-220F、TO-251、TO-252
	SW10N65D	650	10	0.9	1.1	35	30	4.5	Planar	TO-220、TO-220F、TO-220SF、TO-262
	SW11N65D	650	11	0.75	0.9	43	30	4.5	Planar	TO-220、TO-220F、TO-262
SW12N65DA	650	12	0.75	0.9	43	30	4.5	Planar	TO-220SF	
SW12N65D	650	12	0.7	0.8	45	30	4.5	Planar	TO-220、TO-220F、TO-262、TO-263	
SW15N65D	650	15	0.57	0.72	57	30	4.5	Planar	TO-220F	



● HIGH VOLTAGE PLANAR MOSFET - 03

Voltage Rating	Part Number	BV <sub>DSS</sub> (V)	I <sub>D</sub> (A) 25°C	R <sub>DS(ON)</sub> (Ω) (V <sub>GS</sub> =10V)		Q <sub>g</sub> (nC) (V <sub>GS</sub> =10V)	V <sub>GS</sub> (V)	V <sub>GS(th)</sub> (V)	Structure	Package
				Typ.	Max.	Typ.				
650V	SW18N65D	650	18	0.35	0.44	79	30	4.5	Planar	TO-220F、TO-247
	SW20N65D	650	20	0.31	0.4	88	30	4.5	Planar	TO-220F
	SW22N65D	650	22	0.22	0.28	123	30	4.5	Planar	TO-247
700V	SW1N70C	700	1	12.6	16	7.8	30	4.5	Planar	TO-92
	SW2N70D	700	2	5	6.2	11	30	4.5	Planar	TO-220F、TO-251、TO-252、TO-126
	SW4N70D1	700	4	2.1	2.65	18	30	4.5	Planar	TO-251S、TO-251N、TO-251N-S2
	SW4N70D	700	4	2.3	2.7	20	30	4.5	Planar	TO-220F、TO-251、TO-252、TO-251N
	SW6N70DA	700	6	1.7	1.9	26	30	4.5	Planar	TO-220、TO-220F、TO-251、TO-252、TO-251N、TO-251NX、TO-251U、TO-251S
	SW6N70DB	700	6	1.4	1.7	30	30	4.5	Planar	TO-220F、TO-252、TO-251N
	SW6N70D	700	6	1.4	1.7	20	30	4	Planar	TO-220F
	SW6N70A	700	6	1.7	1.75	24	30	4	Planar	TO-251
	SW7N70D	700	7	1.2	1.4	30	30	4.5	Planar	TO-252、TO-251N、TO-262N、TO-220F
	SW8N70D	700	8	1	1.2	37	30	4	Planar	TO-220F、TO-262N
	SW10N70D	700	10	1	1.4	37	30	4.5	Planar	TO-262
	SW12N70D	700	12	0.75	0.87	47	30	4.5	Planar	TO-220F、TO-220SF、TO-220FT、TO-262
SW13N70D	700	13	0.7	0.9	52	30	4.5	Planar	TO-220F	
SW16N70D	700	16	0.54	0.65	67	30	4.5	Planar	TO-220F	
800V	SW1N80A	800	1	13.6	16	6	30	5	Planar	TO-92
	SW4N80D	800	4	3.2	3.8	19	30	4.5	Planar	TO-220F、TO-251N
	SW6N80D	800	6	2	2.4	32	30	4.5	Planar	TO-220F、TO-251、TO-252、TO-251N、TO-262N、TO-262
	SW7N80D	800	7	1.5	1.8	39	30	4.5	Planar	TO-220F、TO-262、TO-262N
	SW10N80D	800	10	1	1.15	55	30	4.5	Planar	TO-220F、TO-251
900V	SW1N90U	900	1	11.7	16	7	30	5	Planar	TO-251
	SW3N90U	900	3	4.8	5.8	19	30	5	Planar	TO-251、TO-251M、TO-252
	SW6N90D	900	6	1.8	2.3	42	30	4.5	Planar	TO-220F、TO-262N
	SW7N90D	900	7	1.7	2.2	42	30	4.5	Planar	TO-220WF
	SW9N90	900	9	1	1.45	74	30	5	Planar	TO-3P
1000V	SW4N100U	1000	4	2.65	3.5	33	30	5	Planar	TO-220F

● HIGH VOLTAGE SUPER JUNCTION (SJ) MOSFET - 01

Voltage Rating	Part Number	BV <sub>DSS</sub> (V)	I <sub>D</sub> (A) 25°C	R <sub>DS(ON)</sub> (Ω) (V <sub>GS</sub> =10V)		Q <sub>g</sub> (nC) (V <sub>GS</sub> =10V)	V <sub>GS</sub> (V)	V <sub>GS(th)</sub> (V)	Structure	Package
				Typ.	Max.	Typ.				
500V	SW4N50K	500	4	0.76	0.9	13	30	4	SJ	TO-220F、TO-251N、TO-252
	SW10N50K	500	10	0.26	0.3	29	30	4	SJ	TO-220、TO-220F、TO-251N、TO-252、TO-247
600V	SW4N60K	600	4	1	1.15	13	30	5	SJ	TO-220F、TO-251、TO-252
	SW6N60K	600	6	0.72	0.85	17	30	5	SJ	TO-220
	SW7N60K	600	7	0.5	0.6	21	30	5	SJ	TO-220F、TO-251
	SW7N60K2F	600	7	0.43	0.5	13	30	4.5	SJ	TO-252
	SW10N60K	600	10	0.37	0.4	29	30	5	SJ	TO-220F
	SW13N60K2	600	13	0.24	0.278	28	30	4	SJ	TO-220F、TO-251、TO-252
	SW16N60K	600	16	0.21	0.23	43	30	5	SJ	TO-220F
	SW20N60K	600	20	0.15	0.18	60	30	5	SJ	TO-220F
	SW38N60K	600	38	0.085	0.095	96	30	5	SJ	TO-247

● HIGH VOLTAGE SUPER JUNCTION (SJ) MOSFET - 02

Voltage Rating	Part Number	BV <sub>DSS</sub> (V)	I <sub>D</sub> (A) 25°C	R <sub>DS(ON)</sub> (Ω) (V <sub>GS</sub> =10V)		Q <sub>g</sub> (nC) (V <sub>GS</sub> =10V)	V <sub>GS</sub> (V)	V <sub>GS(H)</sub> (V)	Structure	Package
				Typ.	Max.					
600V	SW45N60K2	600	45	0.06	0.076	74	30	4.5	SJ	TO-247
	SW45N60K2F	600	45	0.065	0.083	74	30	4.5	SJ	TO-247
	SW47N60K	600	47	0.056	0.07	152	30	5	SJ	TO-247
650V	SW2N65K	650	2	1.9	2.4	7.8	30	4	SJ	TO-251N, TO-252
	SW4N65K	650	4	1	1.25	13	30	4	SJ	TO-220F, TO-251, TO-252
	SW4N65K2	650	4	1.1	1.25	7.1	30	4	SJ	TO-220F, TO-251N, TO-252
	SW5N65K	650	5	0.8	0.95	10.3	30	4	SJ	TO-252
	SW6N65K	650	6	0.8	0.9	17	30	5	SJ	TO-220SF, TO-220F, TO-251, TO-252, TO-262, TO-251N
	SW7N65K	650	7	0.5	0.6	21	30	4	SJ	TO-220SF, TO-220F, TO-251, TO-252, TO-220, TO-251N
	SW7N65K2	650	7	0.57	0.65	14.5	30	4	SJ	TO-220F, TO-251, TO-252
	SW8N65K	650	8	0.53	0.6	20	30	4.5	SJ	TO-262
	SW8N65LA	650	8	0.6	0.75	20	30	4.5	SJ	TO-220SF
	SW10N65K	650	10	0.36	0.4	29	30	5	SJ	TO-220SF, TO-220F, TO-251, TO-252, TO-262, TO-220
	SW10N65K2	650	10	0.3	0.4	21	30	4.5	SJ	TO-220F, TO-252, TO-263
	SW13N65K2	650	13	0.24	0.28	28	30	4	SJ	TO-220, TO-220F, TO-251, TO-252, TO-262, TO-263, DFN5*6, QFN8*8
	SW16N65K	650	16	0.23	0.25	43	30	5	SJ	TO-220, TO-220F, TO-262
	SW20N65K	650	20	0.16	0.19	60	30	5	SJ	TO-220, TO-220F, TO-3P
	SW20N65K2	650	20	0.15	0.19	37	30	4.5	SJ	TO-220F
	SW38N65K	650	38	0.09	0.11	96	30	5	SJ	TO-247
	SW38N65KF	650	38	0.095	0.118	99	30	4	SJ	TO-247
	SW38N65K2	650	38	0.079	0.098	71	30	5	SJ	TO-247
	SW38N65K2F	650	38	0.083	0.1	71	30	4	SJ	TO-220F, TO-247
	SW45N65K2	650	45	0.061	0.077	74	30	4.5	SJ	TO-247
SW45N65K2F	650	45	0.066	0.084	74	30	4.5	SJ	TO-247	
SW47N65K	650	47	0.06	0.072	152	30	5	SJ	TO-247	
SW47N65KF	650	47	0.06	0.072	152	30	4	SJ	TO-247	
SW47N65K2	650	47	0.056	0.072	103	30	4.5	SJ	TO-247	
SW47N65K2F	650	47	0.056	0.072	102	30	5	SJ	TO-247	
SW50N65LF	650	50	0.077	0.095	136	30	4.5	SJ	TO-247	
SW69N65K2	650	69	0.032	0.041	181	30	4	SJ	TO-247	
SW69N65K2F	650	69	0.035	0.041	184	30	4	SJ	TO-247	
700V	SW4N70K	700	4	1	1.3	13	30	5	SJ	TO-220F, TO-251, TO-252
	SW4N70K2	700	4	1.15	1.3	7.1	30	4	SJ	TO-220F, TO-251N, TO-252
	SW4N70L	700	4	0.8	1	18	30	4.5	SJ	TO-220F, TO-251N, TO-252
	SW5N70K	700	5	0.94	1.2	13	30	5	SJ	TO-251N
	SW6N70K	700	6	1.1	1.3	13	30	5	SJ	TO-220F, TO-251N, TO-252
	SW7N70K	700	7	0.81	0.9	17	30	5	SJ	TO-220F, TO-251, TO-252, TO-220
	SW8N70K	700	8	0.55	0.6	21	30	5	SJ	TO-220F, TO-252
	SW10N70K	700	10	0.36	0.42	29	30	5	SJ	TO-220F, TO-252
	SW16N70K	700	16	0.23	0.27	42	30	5	SJ	TO-220F, TO-262, TO-263
	SW20N70K	700	20	0.17	0.2	60	30	5	SJ	TO-220F
800V	SW38N70K	700	38	0.1	0.12	96	30	5	SJ	TO-247
	SW47N70K	700	47	0.065	0.075	152	30	5	SJ	TO-247
	SW4N80K	800	4	1.8	2.1	13	30	4	SJ	TO-220F, TO-251N, TO-252
	SW8N80K	800	8	0.67	0.8	30	30	4	SJ	TO-220F, TO-251, TO-252, TO-262, TO-251N
	SW10N80K2	800	10	0.58	0.65	27	30	4	SJ	TO-220F, TO-251N, TO-252
900V	SW13N80K	800	13	0.44	0.53	42	30	4	SJ	TO-220F
	SW17N80K	800	17	0.31	0.39	57	30	4	SJ	TO-220F, TO-220
	SW2N90K2	900	2	2.2	2.7	13	30	4.5	SJ	TO-220F
SW8N90KU	900	8	0.97	1.2	32	30	4.5	SJ	TO-262N	



● IGBT

Voltage Rating	Part Number	V <sub>CES</sub> (V)	I <sub>c</sub> (A)	Q <sub>s</sub> (nC) (V <sub>GS</sub> =10V) Typ.	V <sub>GE</sub> (V)	V <sub>GE(th)</sub> (V) Typ.	V <sub>CE(sat)</sub> (V) Typ.	Package
600V	SW45N60G	600	30	34	20	3	1.9	TO-220、TO-220F
1200V	SW6N120G	1200	5.3	14	20	7.1	2.5	TO-220F
	SW21N120G	1200	21	53	20	6.8	2.45	TO-220、TO-247、TO-3PN
	SW35N120G	1200	35	100	20	6.8	2.45	TO-220、TO-247、TO-3PN
	SW75N120G	1200	50	200	20	5.5	2	TO-220、TO-247、TO-3P、TO-3PN
	SW160N120G	1200	100	230	20	5.5	2.4	TO-264

● BRIDGE RECTIFIER

Part Number	V <sub>RRM</sub> (V)	I <sub>F(AV)</sub> (A)	I <sub>FSM</sub> (A)	V <sub>F</sub> @ I <sub>F(AV)</sub> (V)	I <sub>R</sub> @ V <sub>RRM</sub> (mA)	Package
MB6F	600	0.8	30	1.1	5	MBF
MB8F	800	0.8	30	1.1	5	MBF
MB10F	1000	0.8	30	1.1	5	MBF
TB6S	600	0.8	30	1.1	5	ABS
TB8S	800	0.8	30	1.1	5	ABS
TB10S	1000	0.8	30	1.1	5	ABS
MB6F-05	600	0.5	20	1.1	5	MBF
MB8F-05	800	0.5	20	1.1	5	MBF
MB10F-05	1000	0.5	20	1.1	5	MBF
TB6S-05	600	0.5	20	1	5	ABS
TB8S-05	800	0.5	20	1	5	ABS
TB10S-05	1000	0.5	20	1	5	ABS
MB6F-10	600	1	35	1.1	5	MBF
MB8F-10	800	1	35	1.1	5	MBF
MB10F-10	1000	1	35	1.1	5	MBF
TB6S-10	600	1	35	1.1	5	ABS
TB8S-10	800	1	35	1.1	5	ABS
TB10S-10	1000	1	35	1.1	5	ABS
MB6F-12	600	1.2	40	1.1	5	MBF
MB8F-12	800	1.2	40	1.1	5	MBF
MB10F-12	1000	1.2	40	1.1	5	MBF

● HIGH EFFICIENCY RECTIFIER DIODE

Part Number	V <sub>RRM</sub> (V)	I <sub>F(AV)</sub> (A)	I <sub>FSM</sub> (A)	V <sub>F</sub> @ I <sub>F(AV)</sub> (V)	I <sub>R</sub> @ V <sub>RRM</sub> (mA)	t <sub>rr</sub> (ns)	Package
US1JW	600	1	30	1.7	5	75	SOD-123FL
US1KW	800	1	30	1.7	5	75	SOD-123FL
US1MW	1000	1	30	1.7	5	75	SOD-123FL
US2JW	600	2	50	1.7	5	75	SOD-123FL
US2KW	800	2	50	1.7	5	75	SOD-123FL
US2MW	1000	2	50	1.7	5	75	SOD-123FL
US1JF	600	1	30	1.7	5	75	SMAF
US1KF	800	1	30	1.7	5	75	SMAF
US1MF	1000	1	30	1.7	5	75	SMAF
US2JF	600	2	50	1.7	5	75	SMAF
US2KF	800	2	50	1.7	5	75	SMAF
US2MF	1000	2	50	1.7	5	75	SMAF
US3JF	600	3	100	1.7	5	75	SMAF
US3KF	800	3	100	1.7	5	75	SMAF
US3MF	1000	3	100	1.7	5	75	SMAF

● FAST RECOVERY DIODE

Part Number	V <sub>RRM</sub> (V)	I <sub>F(AV)</sub> (A)	I <sub>FSM</sub> (A)	V <sub>F</sub> @ I <sub>F(AV)</sub> (V)	I <sub>R</sub> @ V <sub>RRM</sub> (mA)	t <sub>rr</sub> (ns)	Package
FR105W	600	1	30	1.3	5	250	SOD-123FL
FR106W	800	1	30	1.3	5	500	SOD-123FL
FR107W	1000	1	30	1.3	5	500	SOD-123FL
RS12JW	600	1.2	40	1.3	5	250	SOD-123FL
RS12KW	800	1.2	40	1.3	5	500	SOD-123FL
RS12MW	1000	1.2	40	1.3	5	500	SOD-123FL
RS2JW	600	2	50	1.3	5	250	SOD-123FL
RS2KW	800	2	50	1.3	5	500	SOD-123FL
RS2MW	1000	2	50	1.3	5	500	SOD-123FL
RS1JF	600	1	30	1.3	5	250	SMAF
RS1KF	800	1	30	1.3	5	500	SMAF
RS1MF	1000	1	30	1.3	5	500	SMAF
RS2JF	600	2	50	1.3	5	250	SMAF
RS2KF	800	2	50	1.3	5	500	SMAF
RS2MF	1000	2	50	1.3	5	500	SMAF
RS3JF	600	3	100	1.3	5	250	SMAF
RS3KF	800	3	100	1.3	5	500	SMAF
RS3MF	1000	3	100	1.3	5	500	SMAF

● ULTRA FAST RECOVERY DIODE

Part Number	V <sub>RRM</sub> (V)	I <sub>F(AV)</sub> (A)	I <sub>FSM</sub> (A)	V <sub>F</sub> @ I <sub>F(AV)</sub> (V)	I <sub>R</sub> @ V <sub>RRM</sub> (mA)	t <sub>rr</sub> (ns)	Package
ES1GW	400	1	25	1.25	5	35	SOD-123FL
ES1JW	600	1	25	1.7	5	35	SOD-123FL
ES2GW	400	2	50	1.25	5	35	SOD-123FL
ES2JW	600	2	50	1.7	5	35	SOD-123FL
ES1GF	400	1	30	1.25	5	35	SMAF
ES1JF	600	1	30	1.7	5	35	SMAF
ES2GF	400	2	50	1.25	5	35	SMAF
ES2JF	600	2	50	1.7	5	35	SMAF
ES3GF	400	3	100	1.25	5	35	SMAF
ES3JF	600	3	100	1.7	5	35	SMAF

● SCHOTTKY BARRIER DIODE



Part Number	V <sub>RRM</sub> (V)	I <sub>F(AV)</sub> (A)	I <sub>FSM</sub> (A)	V <sub>F</sub> @ I <sub>F(AV)</sub> (V)	I <sub>R</sub> @ V <sub>RRM</sub> (mA)	Package
DS34W	40	3	80	0.55	0.5	SOD-123FL
DS36W	60	3	80	0.70	0.3	SOD-123FL
DS38W	80	3	80	0.70	0.3	SOD-123FL
DS310W	100	3	70	0.85	0.3	SOD-123FL
DS312W	120	3	70	0.85	0.3	SOD-123FL
DS315W	150	3	70	0.95	0.3	SOD-123FL
DS320W	200	3	70	0.95	0.3	SOD-123FL
SS14F	40	1	40	0.55	0.3	SMAF
SS16F	60	1	40	0.70	0.3	SMAF
SS18F	80	1	40	0.70	0.3	SMAF
SS110F	100	1	30	0.85	0.2	SMAF
SS112F	120	1	30	0.85	0.2	SMAF
SS115F	150	1	30	0.90	0.1	SMAF
SS120F	200	1	30	0.90	0.1	SMAF



● APPLICATION

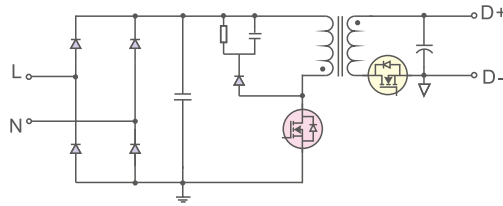

Charger/Adapter



-  600V-800V super junction MOSFET  
500V-900V planar MOSFET
-  30V-60V low voltage MOSFET
-  60V-1000V Diode

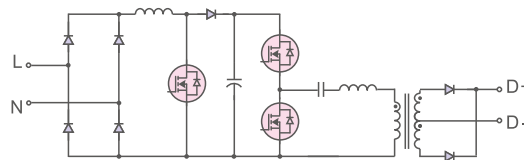
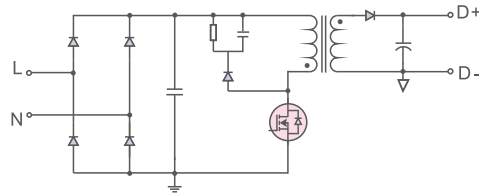



LED Driver

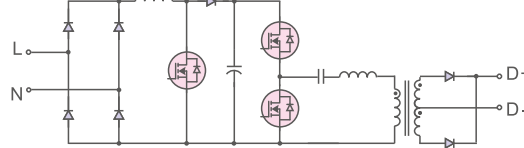
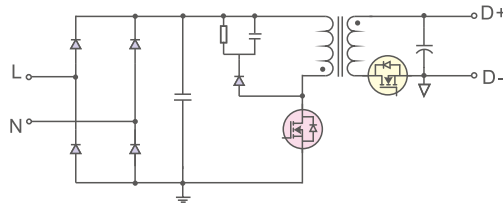

-  600V-800V super junction MOSFET  
500V-900V planar MOSFET
-  60V-1000V Diode



TV Power Supply

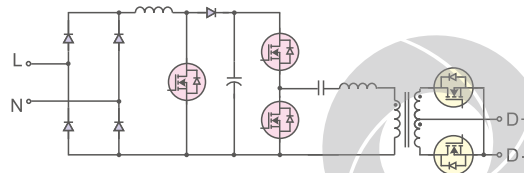

-  600V-700V super junction MOSFET  
500V-700V planar MOSFET
-  30V-60V low voltage MOSFET
-  60V-1000V Diode
-  600V-700V super junction MOSFET  
500V-700V planar MOSFET
-  60V-1000V Diode

PC Power Supply





-  600V-650V super junction MOSFET  
500V-650V planar MOSFET
-  30V-60V low voltage MOSFET
-  60V-1000V Diode

● APPLICATION

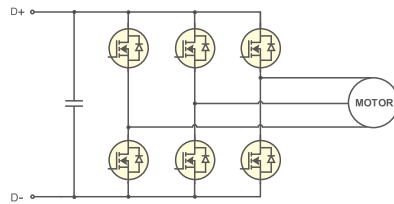
Motor Control





 30V-100V low voltage MOSFET

 60V-1000V Diode

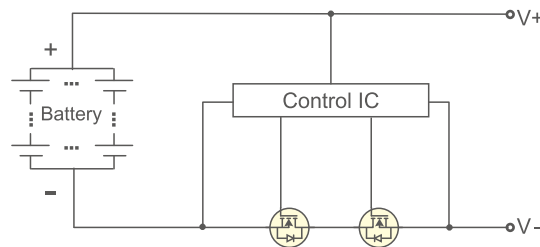
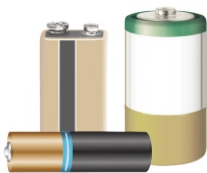
Battery Protection





 30V-100V low voltage MOSFET

 60V-1000V Diode

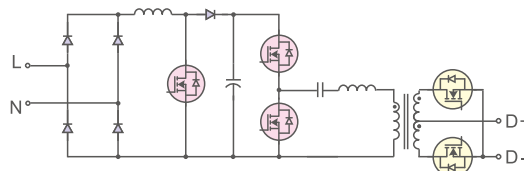
Telecom Power Supply



 600V-650V super junction MOSFET  
 500V-650V planar MOSFET

 30V-60V low voltage MOSFET

 60V-1000V Diode

On-Board Charger

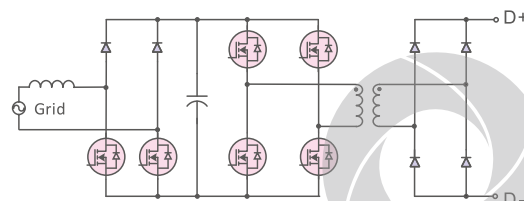



 600V-650V super junction MOSFET

 60V-1000V Diode

● APPLICATION

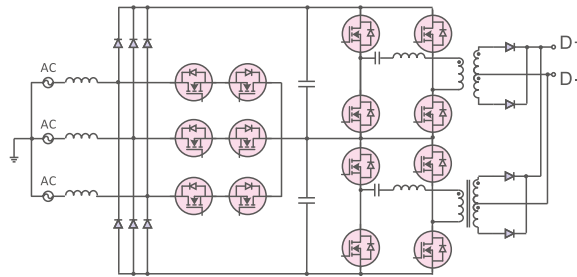

Charging Pile



-  600V-650V super junction MOSFET
-  60V-1000V Diode

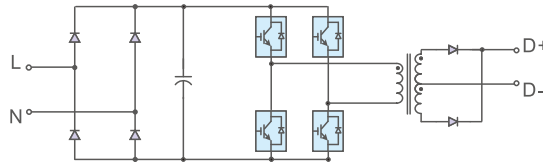



Welding

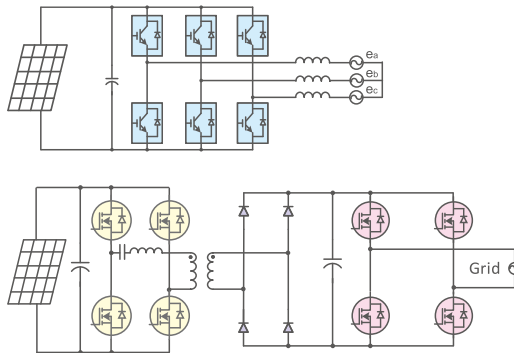

-  600V-1200V IGBT
-  60V-1000V Diode



PV Inverter

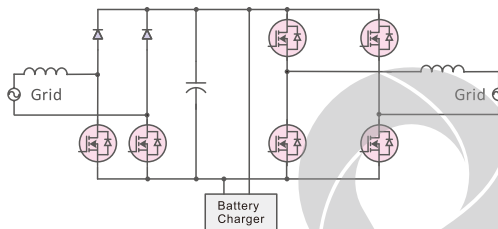

-  600V-1200V IGBT
-  60V-1000V Diode
-  600V-650V super junction MOSFET
-  60V-200V low voltage MOSFET
-  60V-1000V Diode

Micro UPS



-  600V-650V super junction MOSFET
-  60V-200V low voltage MOSFET
-  60V-1000V Diode



# Samwin®

*The Best Choice for Greenpower*

WWW.SAMWINSEMI.COM

#### **Semipower Electronic Technology**

Addr: E101, Huanpu Science and Technology Park, No.8 Tiangu Rd, Hi-Tech Zone,Xi'an, China

Tel: + 086-29-88251977

Fax: + 086-29-88253717

[www.samwinsemi.com](http://www.samwinsemi.com)

[www.semipower.com.cn](http://www.semipower.com.cn)

#### **Samwin South Technology**

Addr: 1503-1505 Room, Cyber Tower A, Tianan Cyber Park, Futian Dis, Shenzhen, China

Tel: + 086-755-83981818

Fax: + 086-755-83476838

[www.samwinsemi.com](http://www.samwinsemi.com)

[www.semipower.com.cn](http://www.semipower.com.cn)

